

BID TABULATION-PARK PAVILION

<b>PARK PAVILION                      BID OPENING                      2-24-15</b>	<b>ALL INCLUSIVE                      REC</b>	<b>PORTER CORP</b>
	109 W LIBERTY FARMINGTON MO 63640	4240 N 136TH HOLLAND MI 49424
<b>BASE BID:</b>		
PAVILION (SIZE ___ X ___) DESIGNED TO SEAT ___ PEOPLE WITH EXPANDED FLOOR SIZE AND WITH DECORATIVE COLUMNS: \$ _____	20 X 44 75 + PEOPLE \$59,248.00	24 X 34 75 PEOPLE \$48,030.00
<b>BID OPTION ONE:</b>		
PAVILION (SIZE ___ X ___) DESIGNED TO SEAT ___ PEOPLE WITH REDUCED FLOOR SIZE AND WITH DECORATIVE COLUMNS: \$ _____	20 X 44 75 + PEOPLE \$56,073.00	24 X 34 75 PEOPLE \$44,330.00
<b>BID OPTION TWO:</b>		
PAVILION (SIZE ___ X ___) DESIGNED TO SEAT ___ PEOPLE WITH EXPANDED FLOOR SIZE AND WITHOUT DECORATIVE COLUMNS: \$ _____	20 X 44 75 + PEOPLE \$58,548.00	24 X 34 75 PEOPLE \$46,470.00
<b>BID OPTION THREE:</b>		
PAVILION (SIZE ___ X ___) DESIGNED TO SEAT ___ PEOPLE WITH REDUCED FLOOR SIZE AND WITHOUT DECORATIVE COLUMNS: \$ _____	20 X 44 75 + PEOPLE \$55,373.00	24 X 34 75 PEOPLE \$42,770.00
<b>BID PICNIC TABLES:</b>		
___ X ___ (INSERT NUMBER) ___ X ___ (INSERT AMOUNT) = \$ _____	13 X \$381.00 = \$4953.00	10 X \$549.00 = \$5490.00
NOTARIZED WORK AFFIDAVIT COMPLETED	YES	YES
COPY OF INSURANCE PROVIDED	YES	YES
TAX RECEIPTS OR NOTARIZED LETTER STATING NO REAL OR PERSONAL PROPERTY OWNED IN JEFFERSON COUNTY	YES	YES
COOPERATIVE BID FORM (Y/N)	YES	YES
COOPERATIVE CONTACT INFO:	NO	YES
COMPANY INFORMATION AND SIGNATURE	NO	NO
BID DEPOSIT REQUIRED	10%	10%
<b>COMMENTS:</b>	See Attached Sheets for Additional Detailed Information.	See Attached Quotes and Additional Project Information.



**JEFFERSON COUNTY**  
**DEPARTMENT OF ADMINISTRATIVE SERVICES**  
 729 MAPLE ST / PO BOX 100  
 HILLSBORO MO 63050  
 WWW.JEFFCOMO.ORG

**Request for Proposal: PARK PAVILION**

**Date Issued: 1-26-15**

PROPOSALS SHALL BE ACCEPTED UNTIL: TUESDAY, FEBRUARY 24, 2015, AT 2:00 P.M. LOCAL TIME.

**Specification Contact:** **MIKE GINGER**  
 Department of Parks and Recreation  
 636-797-5037  
 mginger@jeffcomo.org

**Contract Contact:** **VICKIE PRATT**  
 Department of Administrative Services  
 636-797-5380

**Mail (3) Three Complete Copies With Vendor And Proposal Information As Shown In Sample:**

**SAMPLE ENVELOPE**

<i>VENDOR NAME</i>	
<i>VENDOR ADDRESS</i>	
<i>CONTACT NUMBER</i>	DEPARTMENT OF THE COUNTY CLERK
	JEFFERSON COUNTY MISSOURI
	729 MAPLE ST / PO BOX 100
	HILLSBORO MO 63050-0100
SEALED PROPOSAL: (PROPOSAL NAME)	

**Contract Term:**  
 upon approval by  
 the County Council  
 and County  
 Executive

The undersigned certifies that he/she has the authority to bind this company in an agreement/contract to supply the commodity or service in accordance with all terms, conditions, and pricing specified. This Proposal, if accepted, will constitute an Agreement and Contract with Jefferson County, Missouri, upon approval of the County Council and County Executive. Prices are firm during this agreement term, unless agreed upon in writing by the County. The County has the option to renew this agreement at the same terms and conditions as the original agreement for one additional one-year term with the written consent of the successful bidder. Price increases for renewals are not authorized unless approved in writing by the County.

**Vendor Information:**

Porter Corp Company Name	Brad Hutchinson Authorized Agent (Print)
4240 N 136th Address	 Signature
Holland, MI 499424 City/State/Zip Code	District Sales Consultant Title
800-848-5616 Telephone #	2/23/15 38-1751629 Date Tax ID #
brad@hutchinson-recreation.com E-mail	636-528-8413 Fax #



Poligon C/O  
 Hutchinson Recreation & Design Inc.  
 P.O Box 194  
 Troy, MO 63379

# Poligon A

Name/Address		
Jefferson County Park Department Hillsboro, MO Mike Ginger		
Date	Quotation #	REP
02/23/15	7621	CRH

Terms
-------

Quantity	Description	Total
1	Poligon REK 24' x 34' All Steel Multi-Rib Roof - w/6" Alma decorative columns - w/Gutters & Downspouts - Delivered.	48,030.00T
1	Installation of Poligon Shelter. (For Additional Installation options not listed on quote please view Proposal Facts)	
1	Installation of Gutters and downspouts.	
1	Site excavation - dirt left on-site	
1	Silt Fence	
1	10" Rock Base	
1	Concrete 29'x59'	
1	Footings (4) - based on Poligon Standard footing sizes. **SEE NOTES BELOW	
1	Compaction Test	
1	Flood Plain Development Permit	
Additional ADD ON Options (Not Included in Total):		
ADD (\$5,490.00) for 8' long Redwood Portable Table Stained Southern Yellow Pine Qty (9) and Qty (1) 8' long ADA Redwood Portable Table Stained Southern Yellow Pine - Delivered ONLY.		
ADD (\$350.00) for electrical access. ADD (\$50.00) for EACH electrical cutout desired -		

The acceptance signature below serves as authorization to order the items quoted & indicates acceptance of the listed prices and payment terms enclosed. Signature will not substitute for a Purchase Order.

<b>Total</b>
--------------

Unloading, storage and installation of equipment upon arrival is not included in above pricing unless specifically noted on quote.

Acceptance Signature: \_\_\_\_\_

Signature: \_\_\_\_\_

Phone: (800) 848.5616

www.hutchinson-recreation.com

Fax: (636) 528.8413

**NOTE: Purchase orders & checks for equipment should be made out to Poligon.**



Poligon C/O  
 Hutchinson Recreation & Design Inc.  
 P.O Box 194  
 Troy, MO 63379

# Poligon A

Name/Address		
Jefferson County Park Department Hillsboro, MO Mike Ginger		
Date	Quotation #	REP
02/23/15	7621	CRH

Quantity	Description	Terms
	<p>locations and size of cutouts provided prior to shelter order by customer. This will provide for a clean and hidden look on electrical wiring. Customer to provide all electrical wiring, lighting, etc. for shelter. All electrical to be installed by other during shelter installation for the options above.</p> <p>Please Note:            DEDUCT (\$3,700.00) For reduced concrete area down to 29' x 39'.            DEDUCT (\$1,560.00) For standard columns in lieu of 6" Alma columns.            County to Unload and Store on-site. All pricing based on Poligon standard footing size. Customer to provide soil sample for shelter area prior to shelter order. Footing size and cost may change depending on soil sample. Installation timeline based on turnaround time for submittal approval of drawings by customer, turnaround time/acceptance of any permits required, and any needed changes based on soil sample.            All on-site rough in electrical service and on-site electric items by other. This is not included in our bid.            Tax Exempt</p>	0.00

The acceptance signature below serves as authorization to order the items quoted & indicates acceptance of the listed prices and payment terms enclosed. Signature will not substitute for a Purchase Order.

<b>Total</b>	<b>\$48,030.00</b>
--------------	--------------------

Unloading, storage and installation of equipment upon arrival is not included in above pricing unless specifically noted on quote.

Acceptance Signature: \_\_\_\_\_

Signature: \_\_\_\_\_

Phone: (800) 848.5616

www.hutchinson-recreation.com

Fax: (636) 528.8413

**NOTE: Purchase orders & checks for equipment should be made out to Poligon.**



**JEFFERSON COUNTY**  
**DEPARTMENT OF ADMINISTRATIVE SERVICES**  
 729 MAPLE ST / PO BOX 100  
 HILLSBORO MO 63050  
 WWW.JEFFCOMO.ORG

**Request for Proposal: PARK PAVILION**

**Date Issued: 1-26-15**

PROPOSALS SHALL BE ACCEPTED UNTIL: TUESDAY, FEBRUARY 24, 2015, AT 2:00 P.M. LOCAL TIME.

**Specification  
 Contact:**

**MIKE GINGER**  
 Department of Parks and Recreation  
 636-797-5037  
 mginger@jeffcomo.org

**Contract  
 Contact:**

**VICKIE PRATT**  
 Department of Administrative Services  
 636-797-5380

**Mail (3) Three  
 Complete Copies  
 With Vendor And  
 Proposal  
 Information As  
 Shown In Sample:**

**SAMPLE ENVELOPE**

<i>VENDOR NAME</i>	
<i>VENDOR ADDRESS</i>	
<i>CONTACT NUMBER</i>	
	<b>DEPARTMENT OF THE COUNTY CLERK</b>
	<b>JEFFERSON COUNTY MISSOURI</b>
	<b>729 MAPLE ST / PO BOX 100</b>
	<b>HILLSBORO MO 63050-0100</b>
<b>SEALED PROPOSAL: (PROPOSAL NAME)</b>	

**Contract Term:  
 upon approval by  
 the County Council  
 and County  
 Executive**

The undersigned certifies that he/she has the authority to bind this company in an agreement/contract to supply the commodity or service in accordance with all terms, conditions, and pricing specified. This Proposal, if accepted, will constitute an Agreement and Contract with Jefferson County, Missouri, upon approval of the County Council and County Executive. Prices are firm during this agreement term, unless agreed upon in writing by the County. The County has the option to renew this agreement at the same terms and conditions as the original agreement for one additional one-year term with the written consent of the successful bidder. Price increases for renewals are not authorized unless approved in writing by the County.

**Vendor  
 Information:**

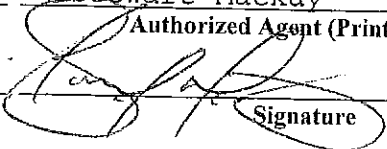
<u>All Inclusive Rec</u>	<u>Stewart Mackay</u>
<b>Company Name</b>	<b>Authorized Agent (Print)</b>
<u>109 W. Liberty/ PO Box 72</u>	
<b>Address</b>	<b>Signature</b>
<u>Farmington, MO 63640</u>	<u>Principal</u>
<b>City/State/Zip Code</b>	<b>Title</b>
<u>573-701-9787</u>	<u>2/20/2015</u>
<b>Telephone #</b>	<b>Date</b>
	<u>30-0284026</u>
	<b>Tax ID #</b>
<u>support@allinclusiverec.com</u>	<u>573-701-9312</u>
<b>E-mail</b>	<b>Fax #</b>

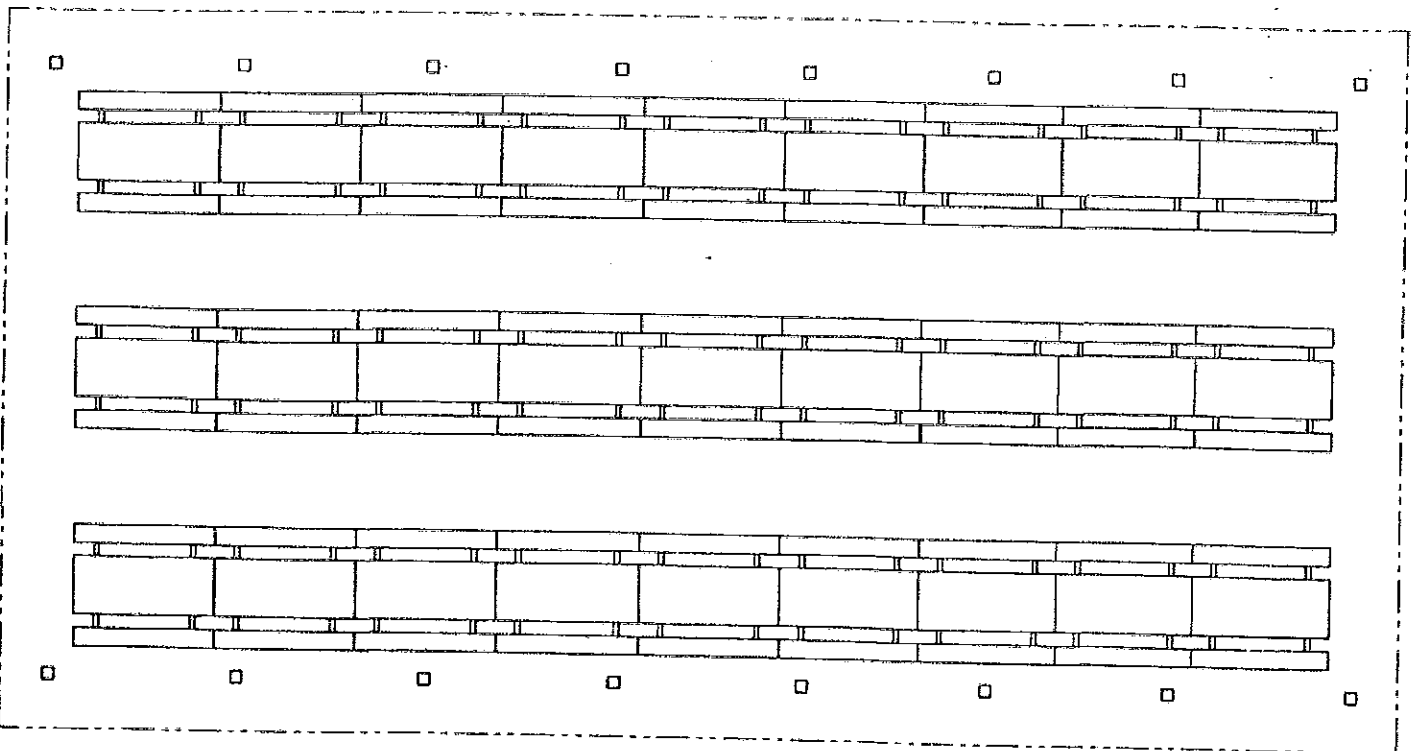
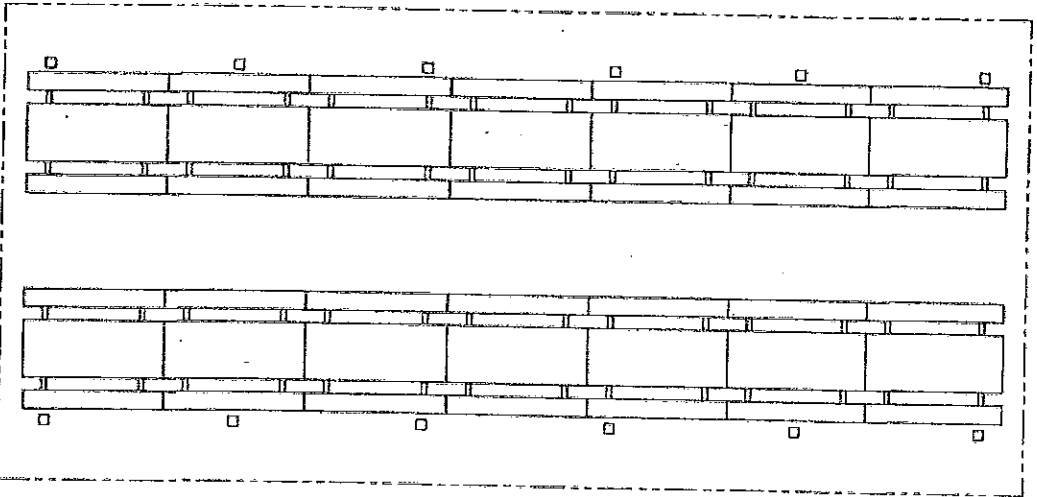
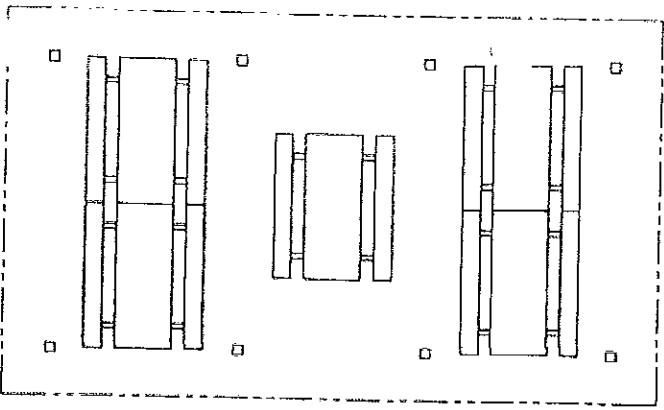

Sq. footage = Length x width

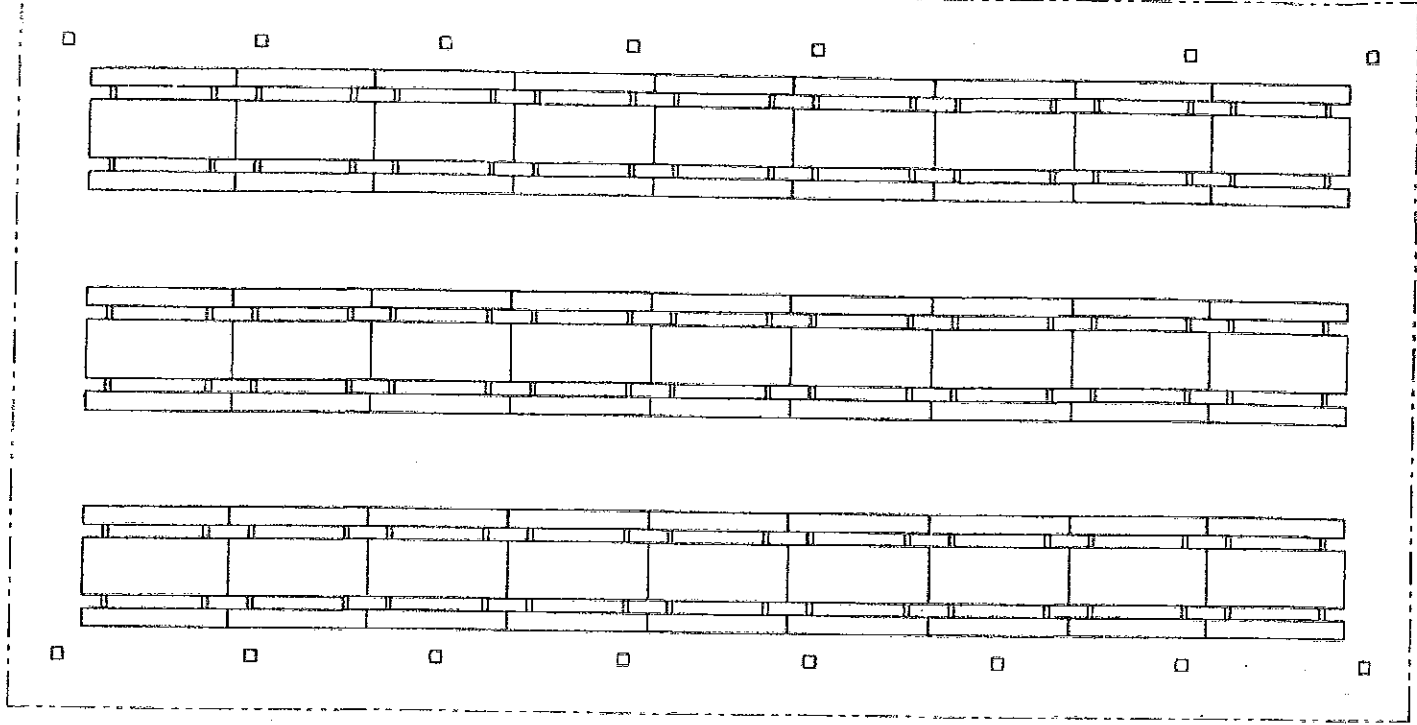

30' x 60'

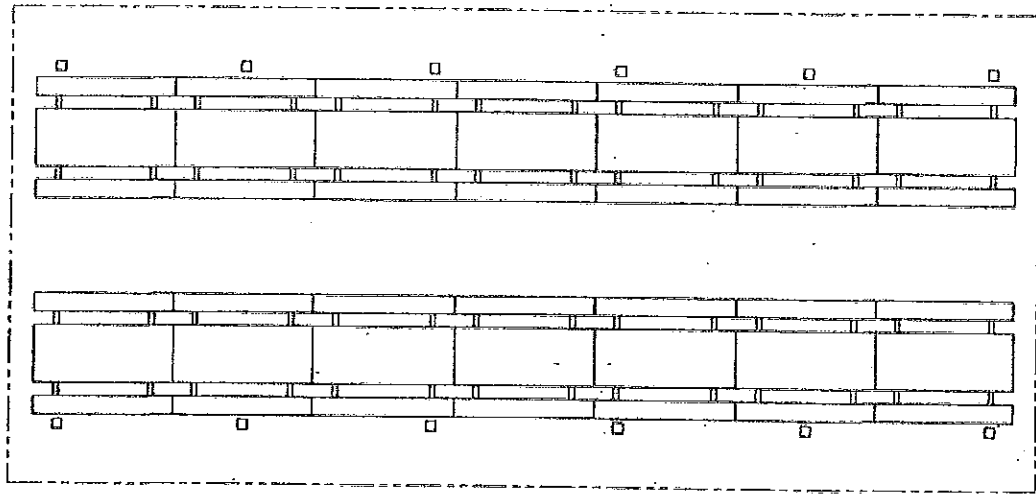

20' x 44'

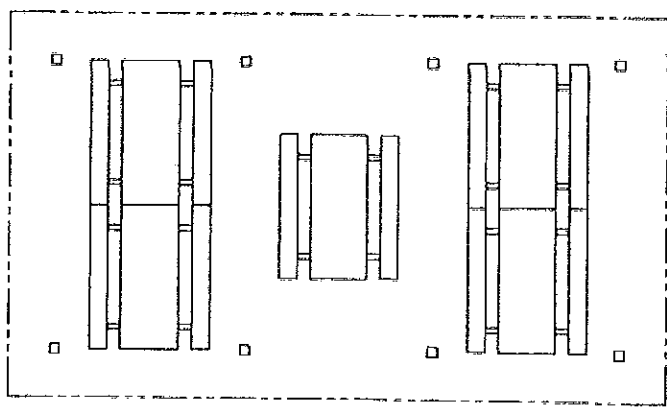

16' x 28'

Sq. footage = Length x width

**Model: Steelworx Gable Shelter, 20' x 44'**  
**Model # GA-2044-SW**

**Manufacturing Mission:** To provide all prefabricated components and installation instructions for a 20' wide (measured from eave to eave) by 44' long free standing bolt together, tubular steel constructed shelter kit.

**Design Criteria:** Structure is typically designed for a 30 lb live load and a 100 mph wind load capacity. All structural members are ASTM A-500 U.S. grade B steel. Welded connection plates shall be ASTM A-36 hot rolled steel. All welding performed to latest AWS standards by ASTM Certified welders and provided in accordance to same.

**Tubular Steel Columns and Beams:** Standard column dimensions shall be 5" x 5" tubular steel welded to 5/8" base plate (footing design provided separately). Interior support beams are 7" x 5" and interior purlins are 5" x 5". Economy Version (EV) of this shelter model for residential or less stringent design locations are available with smaller more economical member sizes.

**Roofing:** 24 Ga. pre-cut steel panels with Kynar 500 finish in a variety of colors with white underside. Standard roof slope is a 4/12 pitch with a eave height of 8'-0". Also available with 6/12 or 8/12 pitch as a single, vented top or double pitch roof. Alternate roofing materials include standing seam, asphalt shingles, cedar shake, or clay tile. Tongue & groove wood decking is also available.

**Frame Finish:** All steel framework will undergo a three step powder coat application that begins with welded raw steel being sand blasted to a white condition to eliminate contaminants and oils. Then a zinc-rich primer is applied and baked at 400°F, followed by a corrosion protective TGIC Polyester powder coat, electro-statically applied and cured at 400°F. A large selection of standard colors are available.

**Foundation:** All columns need to be anchored to concrete footings. Columns can be surface mounted with anchor bolts at or below finish slab elevation or they can be embedded directly into the footing. Optional base plate covers are available at an additional cost.

**Hardware:** All structural hardware provided and to be A-325 or B7 as required.

**Shop Drawing:** The fabricator shall furnish a complete set of installation drawings.

**Not Included:** Concrete work of any kind, unloading of product and installation.

**Additional Options:**

- Flexibility of Design  
Such as: Height and Pitch
- Additional Engineering
- Variety of Colors
- Decorative Railings, Lattice, Braces, Trim, etc.
- Cupolas and Rooftop Accs.
- Site Furnishings and Accs.
- Column Style Variations
- Lexan Wind Screens
- Tongue & Groove Roof Decking
- Asphalt Shingles, Standing Seam, Cedar Shake or Clay Tile Roofing
- Composite Finished Ceiling
- Solar Panels & Solar Lighting

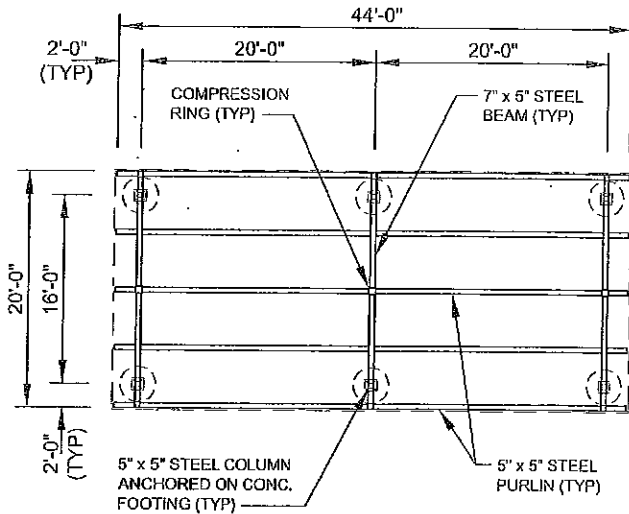

**FRAMING PLAN**  
SCALE: NTS

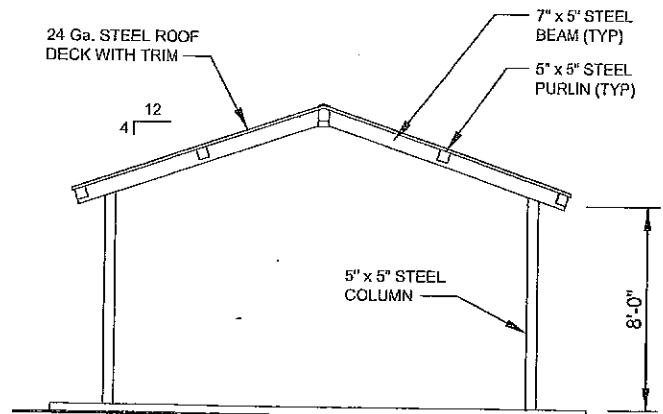

**ELEVATION**  
SCALE: NTS



11800 East 9 Mile Road  
 Warren, MI 48089  
 Office: (586) 486-1088  
 Fax: (586) 764-9130  
 Toll Free: (800) 657-6118  
 Email: info@coverworx.net  
 www.CoverWorx.net

**Steelworx Gable Shelter - 20' x 44'**

**Model: GA-2044SW**

**DESIGN SPECIFICATIONS**



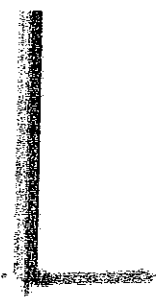

**STANDARD**



**STANDARD**  
W/ BASE

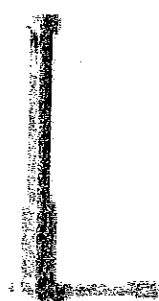

**STANDARD**  
W/ BASE & CAP



**STANDARD**  
W/ BASE & BANDS

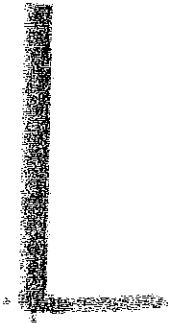

**ROUND**

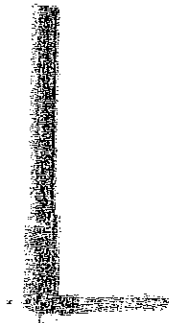

**ROUND**  
W/ BASE

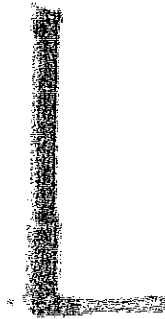

**ROUND**  
W/ BASE & CAP

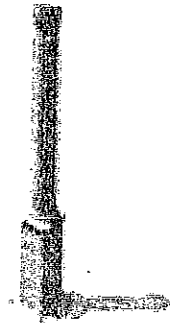

**ROUND**  
W/ DENTAL

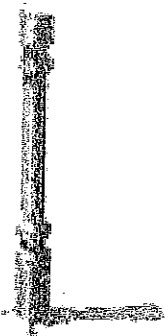

**BANDED**

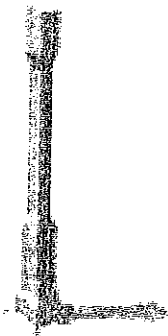

**CLASSIC**

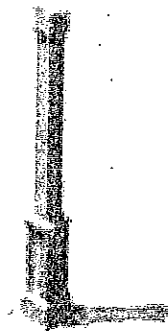

**DRAFTSMAN**

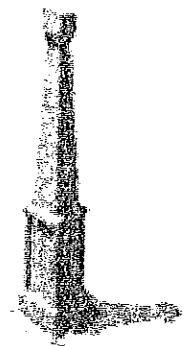

**TAPERED**  
**DRAFTSMAN**

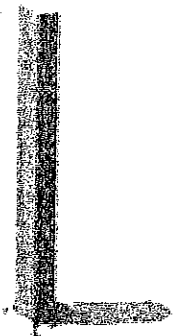

**OVERSIZED**

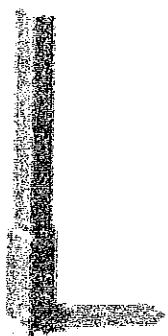

**OVERSIZED**  
W/ BASE

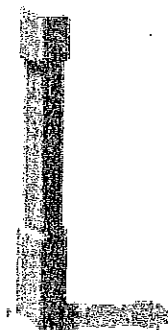

**OVERSIZED**  
W/ BASE & CAP

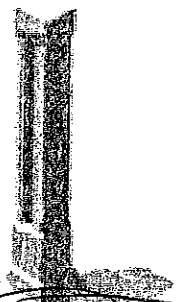

**WORK**

